

Service Manual

AUTOMOTIVE ELECTRONICS

COMPACT
disc
DIGITAL AUDIO



V.W. CQ-JV1060L

AM/FM MPX ELECTRONIC TUNING
RADIO with Stereo Cassette Tape
Player and CD Player

V.W. PART No. : 3B7 035 180

VEHICLE : PASSAT, GOLF, JETTA

DESTINATION : North America

PRODUCED AFTER : Aug., 2001

Specification*

General

Power Supply	DC 12V (11V - 16V), Test Voltage 14.4V Negative Ground
Current Consumption	Less than 2.5A (0.5W×4ch)
Power Output	45W×4ch (at 0.5W)
Speaker Impedance	4Ω

AM Radio

Frequency Range	530 - 1,710kHz
Usable Sensitivity	23dB/μV (S/N 20dB)

FM Stereo Radio

Frequency Range	87.9 - 107.9MHz
Usable Sensitivity	4dB/μV (S/N 26dB)

CD Player	
Decoding	16bit (Linear)
Signal to Noise Ratio	More than 70dB (IHF-A)
Channel Separation	More than 50dB (IHF-A)
Dimensions**	189(W)×111(H)×170(D)mm
Weight**	2.6kg

* Specifications and the design are subject to possible modification without notice due to improvements.

** Dimensions and Weight shown are approximate.

Dolby noise reduction manufactured under license from Dolby Laboratories Licensing Corporation.

"Dolby" and the double-D symbol  are trade marks of Dolby Laboratories Licensing Corporation.

WARNING

This service information is designed for experienced repair technicians only and is not designed for use by the general public. It does not contain warnings or cautions to advise non-technical individuals of potential dangers in attempting to service a product. Products powered by electricity should be serviced or repaired only by experienced professional technicians. Any attempt to service or repair the product or products dealt with in this service information by anyone else could result in serious injury or death.

IMPORTANT SAFETY NOTICE

There are special components used in this equipment which are important for safety. These parts are marked by  in the Schematic Diagrams, Circuit Board Diagrams, Exploded Views and Replacement Parts List. It is essential that these critical parts should be replaced with manufacturer's specified parts to prevent shock, fire or other hazards. Do not modify the original design without permission of manufacturer.

Panasonic®

© 2001 Matsushita Communication Industrial Co., Ltd. All rights reserved. Unauthorized copying and distribution is a violation of law.

CONTENTS

Page	Page
1 FEATUERS 2	9 REPLACEMENT PARTS LIST 13
2 LASER PRODUCTS 2	10 EXPLODED VIEW (Unit) 21
3 REAR VIEW 2	11 CD PLAYER PARTS 22
4 FRONT VIEW AND FUNCTIONS 3	12 EXPLODED VIEW (CD Deck) 23
5 WIRING CONNECTION 4	13 TAPE PLAYER PARTS 24
6 BLOCK DIAGRAM 5	14 EXPLODED VIEW (Tape Deck) 25
7 TERMINALS DESCRIPTION 8	15 WIRING DIAGRAM 26
8 PACKAGE AND IC BLOCK DIAGRAM 10	16 SCHEMATIC DIAGRAM 35

1 FEATUERS

- PLL (Phase Locked Loop) synthesized tuning.
- 12-FM, 12-AM presets with preset scan
- Dolby noise reduction.
- NCD-8 CD player.
- CD Changer control.

2 LASER PRODUCTS

Do not take apart this unit or attempt to make any changes yourself.

This unit is very intricate that uses a laser pickup to retrieve information from the surface of compact discs. The laser is carefully shielded so that its rays remain inside the cabinet. Therefore, never try to disassemble the player or alter any of its parts since you may be exposed to laser rays and dangerous voltages.

Laser products :

Wave length 780nm
 Laser power No hazardous radiation is emitted with safety protection.

Caution

This product utilizes a laser. Use of controls or adjustments or performance of procedures other than those specified herein may result in hazardous radiation exposure.

3 REAR VIEW

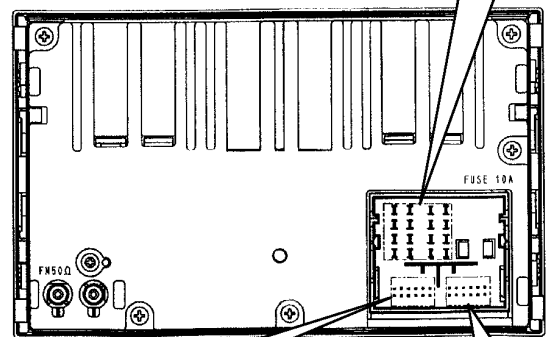
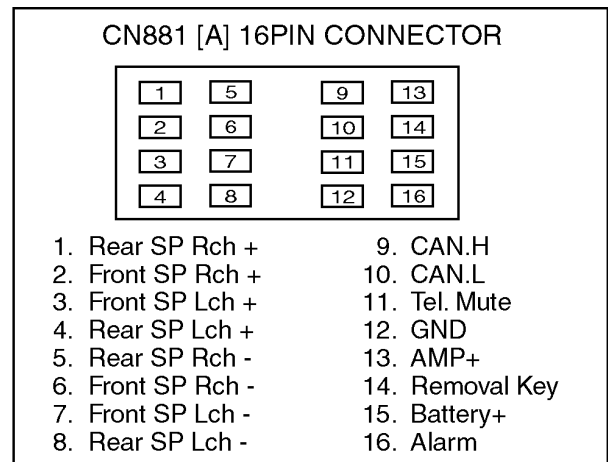

CN881 [B] 12PIN CONNECTOR

1	2	3	4	5	6
7	8	9	10	11	12

1. OPEN
2. CDC.S.GND
3. OPEN
4. CDC BATT
5. OPEN
6. CD-REMO
7. OPEN
8. CDC.L
9. CDC.R
10. CDC-CONT
11. CD-DATA
12. CD-CLK

CN881 [C] 12PIN CONNECTOR

1	2	3	4	5	6
7	8	9	10	11	12

1. OPEN
2. OPEN
3. OPEN
4. OPEN
5. OPEN
6. OPEN
7. OPEN
8. OPEN
9. OPEN
10. OPEN
11. OPEN
12. OPEN

4 FRONT VIEW AND FUNCTIONS

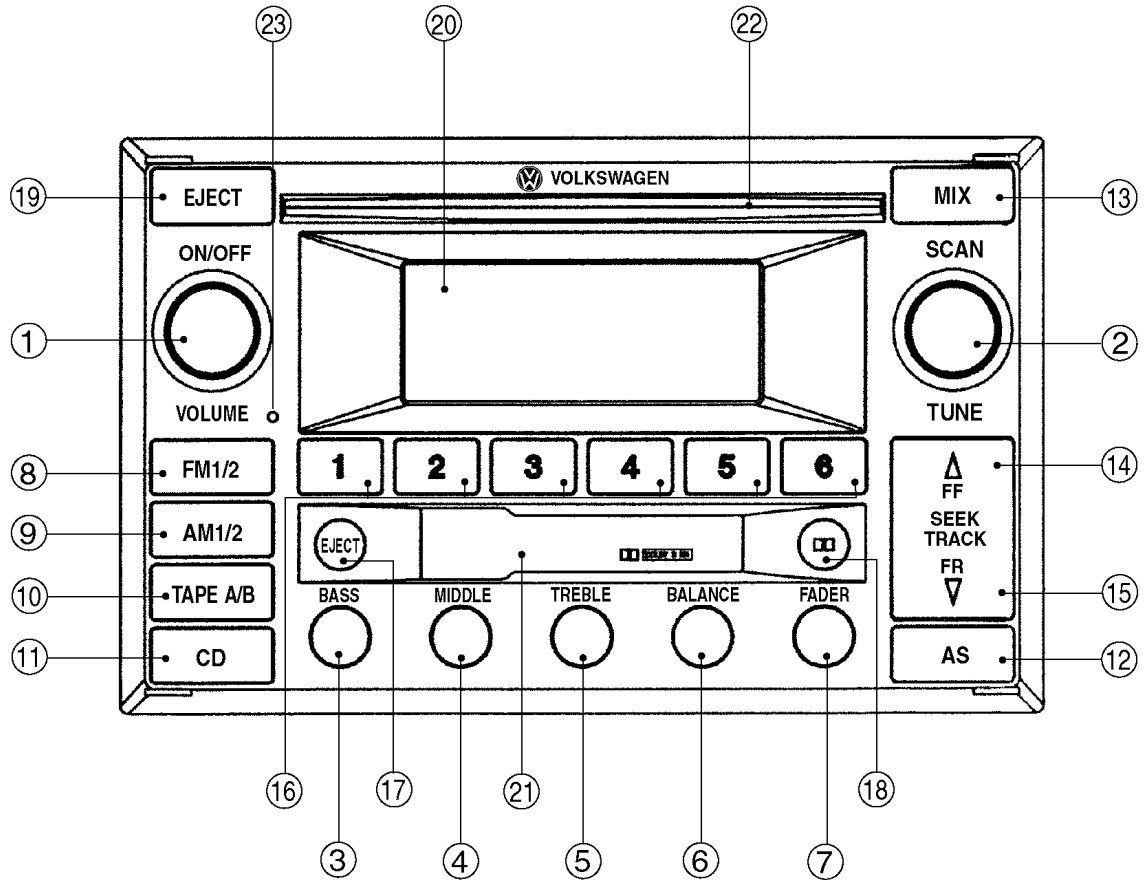

- | | | | | | |
|---|----------|----------------------------------|---|----------------|--------------------------------|
| ① | PUSH PWR | : Power on/off. | ⑭ | SEEK ▲ | : Radio seek up. |
| | VOL | : Volume control. | | TRACK ▲ | : CD track up / TPS FF. |
| ② | TUNE | : Radio manual tuning. | | FF ▲ | : CD/Tape fast-forward. |
| | SCAN | : Scan tuning / Scan play. | ⑮ | SEEK ▼ | : Radio seek down. |
| ③ | BASS | : Bass adjustment mode. | | TRACK ▼ | : CD track down / TPS REW. |
| ④ | MIDDLE | : Middle adjustment mode. | | FR ▼ | : CD/Tape fast-reverse. |
| ⑤ | TREBLE | : Treble adjustment mode. | ⑯ | 1 ~ 6 | : Radio frequency preset/call. |
| ⑥ | BALANCE | : Balance adjustment mode. | | | : CD CH disc selection. |
| ⑦ | FADER | : Fader adjustment mode. | ⑰ | EJECT | : Tape eject. |
| ⑧ | FM 1/2 | : FM radio selection. | ⑱ | ■ | : Dolby on/off. |
| ⑨ | AM 1/2 | : AM radio selection. | ⑲ | EJECT | : CD eject. |
| ⑩ | TAPE A/B | : Tape play / Tape side change. | ⑳ | LCD display. | |
| ⑪ | CD | : CD player / CD.CH selection. | ㉑ | Cassette slot. | |
| ⑫ | AS | : Radio band auto-store. | ㉒ | CD slot. | |
| ⑬ | MIX | : CD player / CD.CH random play. | | | |

5 WIRING CONNECTION

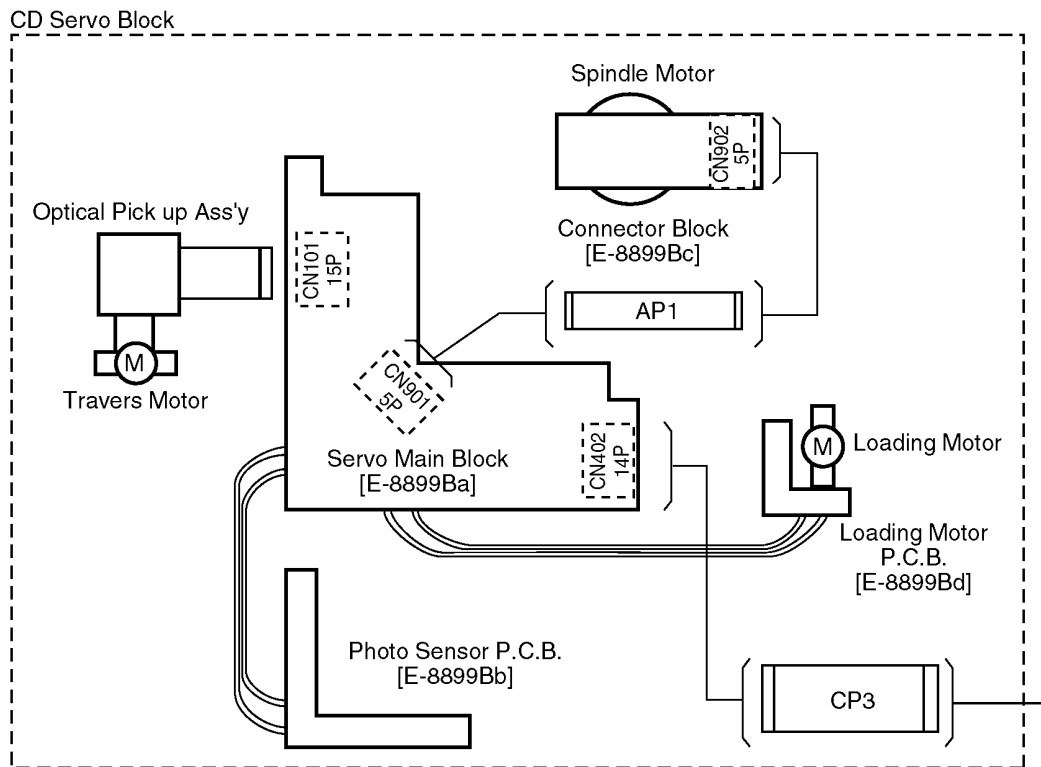
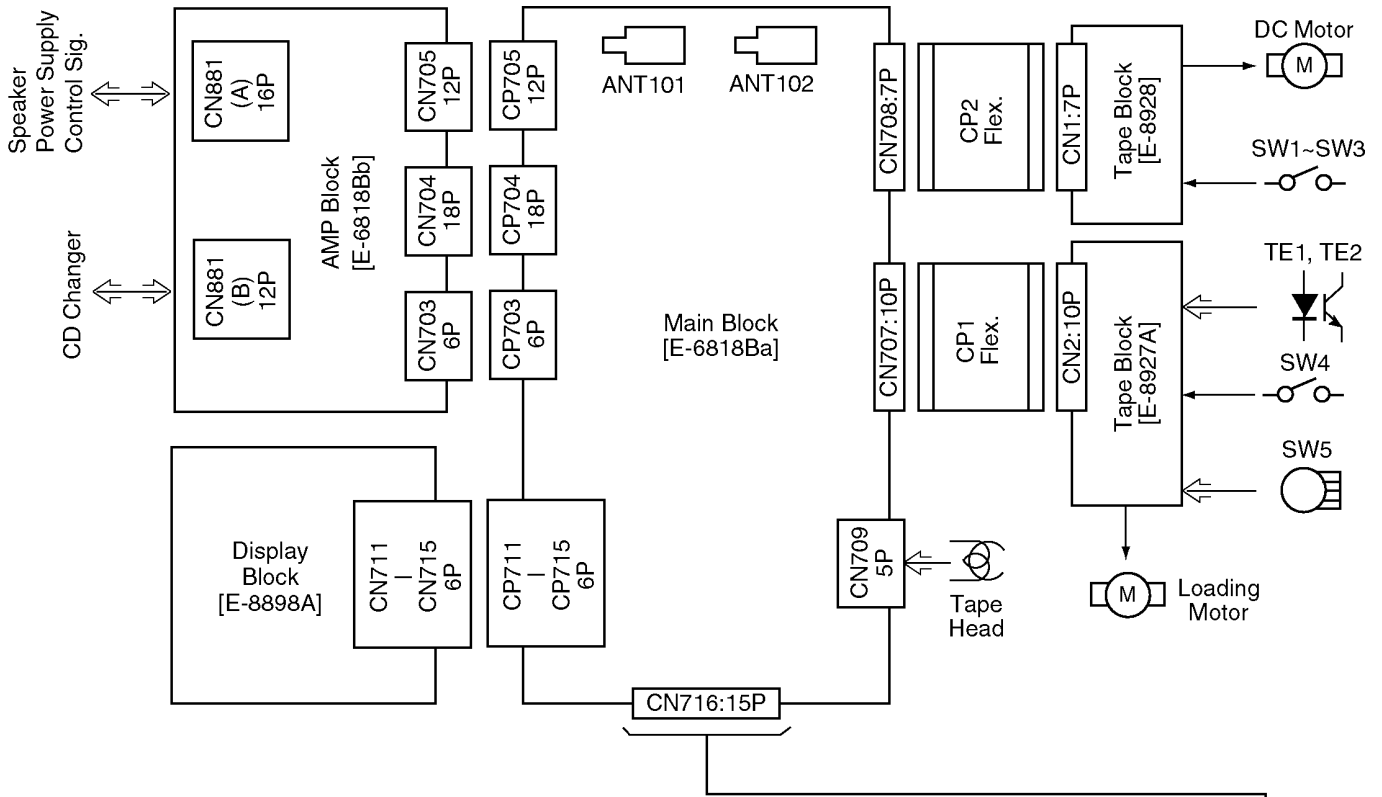

6.2. AMP Block

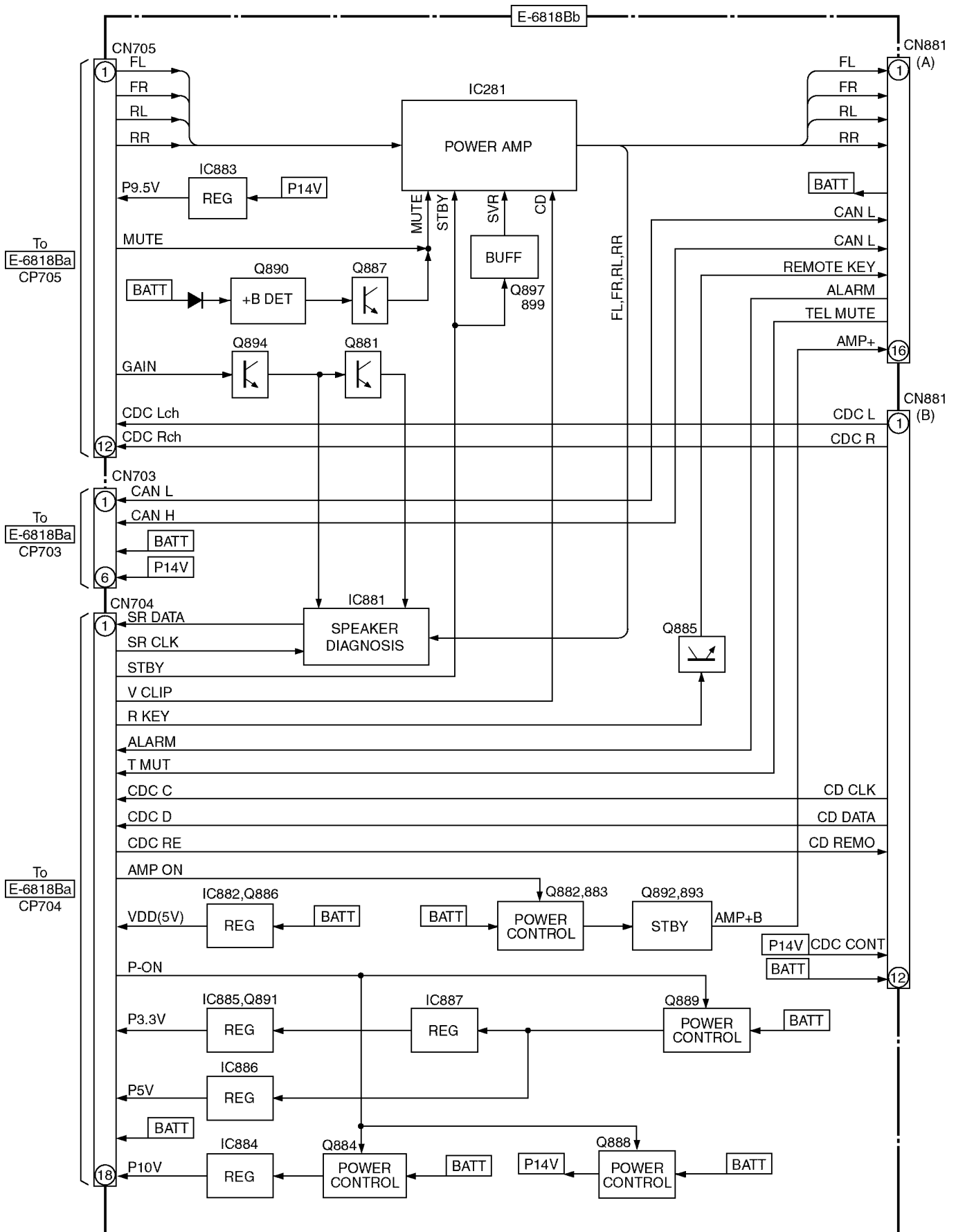

7 TERMINALS DESCRIPTION

7.1. Main Block

IC701 : C2CBKA00001

Pin No.	Port	Descriptions	I/O	Vol. (V)
1	RSTOUT	Not used	-	-
2	NMI	(VDD pull-up)	-	4.8
3	VSS	Ground	-	0
4	VDD	+5V power supply	-	4.8
5	LCD.ADR	LCD address	O	0
6	CD.SW3	CD disc out	I	4.4
7	CD.SW1	CD disc in	I	4.5
8	P.ON	System power on	O	4.8
9	CAN6.1V	Battery level detection (6.1V)	I	4.7
10	SAFE	Safety LED control	O	4.8
11	ILL2	Illumi. on (LCD)	O	4.8
12	ILL	Illumi. on (Button)	O	4.8
13	KI0	Key data input	I	0
14	KI1	Key data input	I	0
15	KI2	Key data input	I	0
16	KI3	Key data input	I	0
17	VSS	Ground	-	0
18	VDD	+5V power supply	-	4.8
19	SR.DATA	Serial data	I/O	4.8
20	SR.CLK	Clock for serial data	O	4.8
21	ANT.CNT	ANT1 amp power control	O	0
22	A/B.IN	Tape side detection	I	4.7
23	TUN.A	Tuning/Scan SW	I	0
24	TUN.B	Tuning/Scan SW	I	0
25	VSS	Ground	-	0
26	VDD	+5V power supply	-	4.8
27	DEV	FM deviation	I	0
28	ADJ	FM adjacent interference	I	0
29	M.P	FM multipath interference	I	0
30	FILD	Fieldstrength level	I	0.5
31	IF.V	ANT2 current intensity	I	0.5
32	ANT.V	ANT1 current intensity	I	0.5
33	BATT.V	Battery level detection	I	2.6
34	FAD	Fader level	I	2.3
35	VA.REF	+5V power supply	-	4.8
36	VA.GND	Ground	-	0
37	BAL	Balance level	I	2.3
38	TRE	Treble level	I	0
39	MID	Middle level	I	1.0
40	BASS	Bass level	I	1.0
41	VSS	Ground	-	0
42	VDD	+5V power supply	-	4.8
43	BAT.DET	Battery level detection	I	4.8
44	CC.EJ	Tape eject	I	4.8
45	CD.EJ	CD eject	I	1.8
46	ALARM	Alarm signal	I	0
47	P.SW	Power on SW	I	4.8
48	CD.SW2	CD SW2 input	I	0
49	T.LOAD	Tape loading detection	I	0
50	DIAG.CONT	Not used	-	-
51	VSS	Ground	-	0
52	VDD	+5V power supply	-	4.8
53	IF.ON	ANT2 amp power control	O	0
54	RADIO.ON	Radio power control	O	4.8
55	DSP.DET	DSP in activity	I	4.8
56	CD.RST	CD reset	O	4.8
57	CD.SIM0	CD serial data	O	0
58	CD.ON	CD controller enable	O	0
59	BIT3	Tape mode SW	I	0
60	BIT2	Tape mode SW	I	0
61	CDC.REMO	CD.CH remoon data	O	0
62	CDC.DATA	CD.CH data	I	0
63	BIT1	Tape mode SW	I	0
64	EQ	Metal tape detection	I	0
65	MS	MS detection	I	0
66	CDC.CLK	Shift clock for CD.CH data	O	0
67	LCD.DET	LCD driver in activity	I	0

Pin No.	Port	Descriptions	I/O	Vol. (V)
68	VDD	+5V power supply	-	4.8
69	VSS	Ground	-	0
70	CD.SOMI	CD serial data	I	0
71	/T.MUT	Telephon mute	I	0
72	CD.SCKM	Shift clock for CD data	O	0
73	CAN.EN	CAN BUS enable	O	0
74	CAN.STB	CAN BUS strobe	O	0
75	CAN.RX	CAN BUS data	I	4.8
76	CAN.TX	CAN BUS data	O	4.8
77	CAN.N.ERR	CAN BUS error	I	4.8
78	VDD	+5V power supply	-	4.8
79	VSS	Ground	-	0
80	/RD	Not used	-	-
81	/WR	Not used	-	-
82	/READY	Not used	-	-
83	ALE	Not used	-	-
84	/EA	(VDD pull-up)	-	0
85	K00	Key scan	O	1.2
86	K01	Key scan	O	1.2
87	K02	Key scan	O	0
88	K03	Key scan	O	1.2
89	PL04	Not used	-	-
90	R.IN	Tape reverse	O	0
91	T.IN	Tape-in detection	I	0
92	ENDA	Tape end detection	I	0
93	VDD	+5V power supply	-	4.8
94	VSS	Ground	-	0
95	CD.ON10V	CD power on (10V)	O	4.6
96	M2F	Main motor control	O	4.8
97	CC.ON	Tape power on	O	0
98	ENDB	Tape end detection	I	0
99	GAIN	Audio output level control	O	4.8
100	CD.ON5V	CD power on (5V)	O	4.8
101	F.IN	Tape forward	O	0
102	LCD.ON	LCD driver reset	O	4.8
103	E2DATA	Security data	I	0
104	ST-BY	Power amp stand-by	O	4.8
105	DSP.RST	DSP reset	O	4.8
106	AMP.ON	External AMP power on	O	0
107	MUT	Not used	-	4.8
108	M2	Main motor control	O	0
109	VOL.A	Volume control signal	I	0
110	VOL.B	Volume control signal	I	0
111	VDD	+5V power supply	-	4.8
112	VSS	Ground	-	0
113	E2CE	Security ROM chip enable	O	0
114	LCD/E2 DT	LCD/Security data	O	0
115	LCD/E2 CK	Clock for LCD/Security data	O	0
116	LCD CS2	LCD driver select	O	0
117	F/E.STP	Radio stopsignal input	I	0.9
118	F/E.DATA	Tuner control data	O	0
119	F/E.ENA	Tuner enable	O	0
120	F/E.CLK	Shift clock for control data	O	0
121	VDD	+5V power supply	-	4.8
122	VSS	Ground	-	0
123	XTAL2	Crystal oscillator	-	2.0
124	XTAL1	Crystal oscillator	-	2.3
125	VSS	Ground	-	0
126	XTAL3	Crystal oscillator	-	2.3
127	XTAL4	Crystal oscillator	-	2.3
128	RST	Reset	I	4.9

Note 1 : Voltage measuerments are with respect to ground, with a voltmeter (internal resistance : 10M ohms).

7.2. CD Servo Block

IC402 : MN662783RPW

Pin No.	Port	Descriptions	I/O	Vol. (V)
1	VDD	+5V power supply	-	5.0
2	D0	D-RAM data	I/O	2.3
3	D1	D-RAM data	I/O	1.8
4	NWE	D-RAM data write	O	4.9
5	NRAS	D-RAM row address strobe	O	3.4
6	D2	D-RAM data	I/O	0.8
7	D3	D-RAM data	I/O	0
8	NCAS0	D-RAM column address strobe	O	3.9
9	A10	D-RAM address	O	3.9
10	A8	D-RAM address	O	0.6
11	A7	D-RAM address	O	1.1
12	A6	D-RAM address	O	0.7
13	A5	D-RAM address	O	0
14	A4	D-RAM address	O	1.1
15	A9	D-RAM address	O	0.4
16-18	A0	D-RAM address	O	1.0
19	A3	D-RAM address	O	0
20	DVSS	Ground	-	0
21	DVDD	+5V power supply	-	5.0
22,23	-	Not used	-	-
24	TVD	Traverse motor control	O	2.5
25	PC	Not used	-	-
26	ECS	Spindle motor control	O	2.4
27	TRD	Tracking coil drive	O	2.5
28	FOD	Focus coil drive	O	2.4
29	FBAL	Focus balance	O	1.9
30	TBAL	Tracking balance	O	3.0
31	VREF	Refence voltage	I	2.5
32	FE	Focus error	I	2.5
33	TE	Tracking error	I	2.5
34	RFENV	RF envelope	I	2.5
35	OFTR	Off track signal	I	0
36	/RFDET	RF detecting signal	I	0
37	BDO	Drop-out signal	I	0
38	LDON	Laser on signal	O	4.5
39	ARF	RF signal	I	2.5
40	IREF	Reference current input	I	1.2
41	DRF	Bias for DSL	I	2.4
42	DSLF	Loop filter for DSL	I/O	2.5
43	DSL2	Loop filter for DSL	I/O	2.2
44	PLLF	Loop filter for PLL	I/O	1.4
45	VCOF	Not used	-	-
46	AVDD	+5V power supply	-	5.0
47	AVSS	Ground	-	0
48	OUTL	L channel output	O	2.3
49	AVSS	Ground	-	0
50	OUTR	R channel output	O	2.3
51	AVDD	+5V power supply	-	4.7
52-54	-	(Connecting to ground)	-	0
55	FLAG	Flag output	O	0
56	FCLK	Frame clock	O	0
57-59	-	Not used	-	-
60	TX	Not used	-	-
61	MCLK	Clock for I/F command	I	1.0
62	MDATA	Date for I/F command	I	3.1
63	MLD	I/F command load	I	5.0
64	BLKCK	Subcode block clock	O	0
65	SQCK	Ext.clock for sub code-Q	I	5.0
66	SUBQ	Code for sub. code-Q	O	3.8
67	DMUTE	Mute input	I	0
68	STAT	Status signal	O	5.0
69	NRST	Reset input	I	5.0
70	CSEL	(Connecting to ground)	-	0
71	PMCK	Clock output	O	2.5
72	SMCK	Clock output	O	2.5
73	SUBC	Serial data of sub code	O	0
74	SBCK	Shift clock for SUBC	I	0.6
75	NCLDCK	Not used	-	-
76	NTEST	(Connecting to VDD)	-	5.0

Pin No.	Port	Descriptions	I/O	Vol. (V)
77	X1	Crystal oscillator	-	0.4
78	X2	Crystal oscillator	-	3.2
79	DVDD	+5V power supply	-	5.0
80	DVSS	Ground	-	0

IC401 : MN101C30AAE

Pin No.	Port	Descriptions	I/O	Vol. (V)
1	SW4	Disc clamp detection	I	0
2	SW5	Inner track detection	I	5.0
3	SW2	Feeder arm detection	I	4.8
4	PAG	(Connecting to ground)	-	0
5	IFR	(Connecting to ground)	-	0
6	VREF+	+5V power supply	-	5.0
7	VDD	+5V power supply	-	5.0
8	OSC2	Crystal oscillator	-	2.2
9	OSC1	Crystal oscillator	-	2.1
10	VSS	Ground	-	0
11	XI	(Connecting to ground)	-	0
12	XO	Not used	-	-
13	GND	Ground	-	0
14	SOMI	CD changer serial data	O	4.3
15	SIMO	CD changer serial data	I	1.3
16	SCKM	Clock for serial data	I	5.0
17	SB01	Not used	-	-
18	SUBQ	Code for sub. code-Q	I	1.6
19	SQCK	Ext. clock for sub. code-Q	O	5.0
20	P0G	Not used	-	-
21	RST	Reset input	I	4.9
22	BD0	Drop-out signal	I	0
23	PC1	Loading motor driver control	O	5.0
24-26	-	Not used	-	-
27	CDON	CD activity	I	5.0
28	BLKCK	Subcode block clock	O	0
29-31	-	Not used	-	-
32	PC2	Focus/Tracking driver control	O	0
33-36	-	Not used	-	-
37	LOD	Loading motor control	I/O	2.5
38	TRV	Traverse motor control	I/O	2.4
39	NRST	Servo IC reset	O	5.0
40	STAT	Status signal	I	2.1
41	DMUTE	DSP mute	O	0
42-55	-	Not used	-	-
56	MASHON	Servo IC OSC control	O	0.2
57	MCLK	Command clock	O	4.1
58	MDATA	Command data	O	3.1
59	MLD	Command load	O	5.0
60	P80	Not used	-	-
61	VREF-	(Connecting to ground)	-	0
62	Q1	Photo sensor signal (DISC IN)	I	4.5
63	Q3	Photo sensor signal (DISC OUT)	I	4.2
64	Q6	Photo sensor signal (Option)	I	5.0

8 PACKAGE AND IC BLOCK DIAGRAM

8.1. Main Block

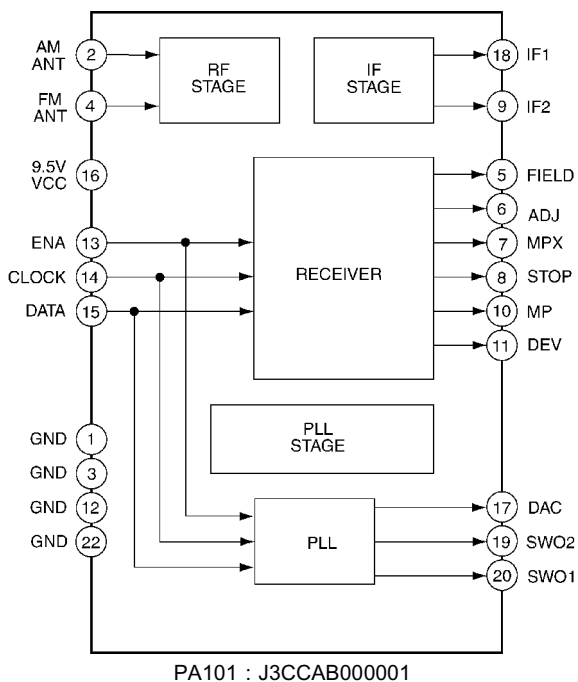

PA101 : J3CCAB000001

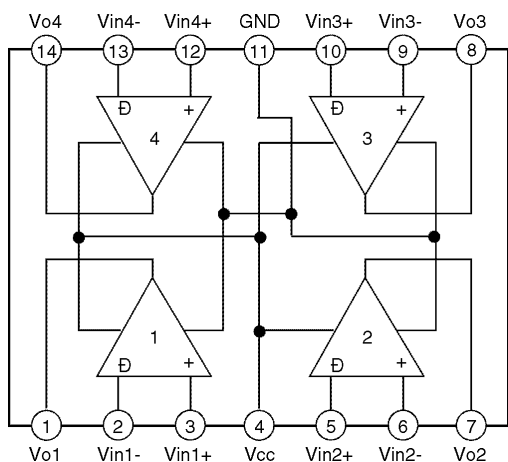

IC102 : AN6564NST1

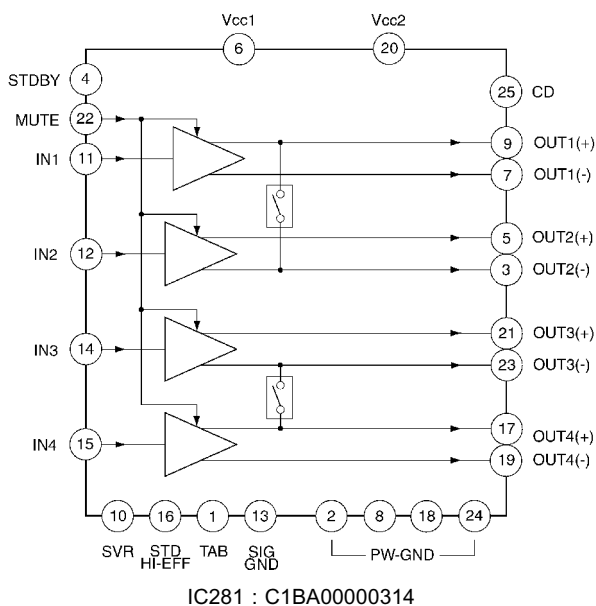

IC281 : C1BA00000314

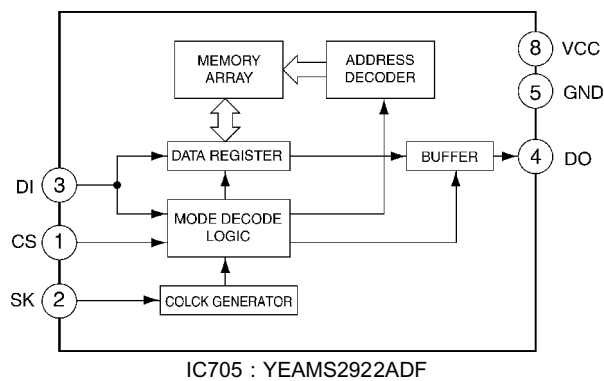

IC705 : YEAMS2922ADF

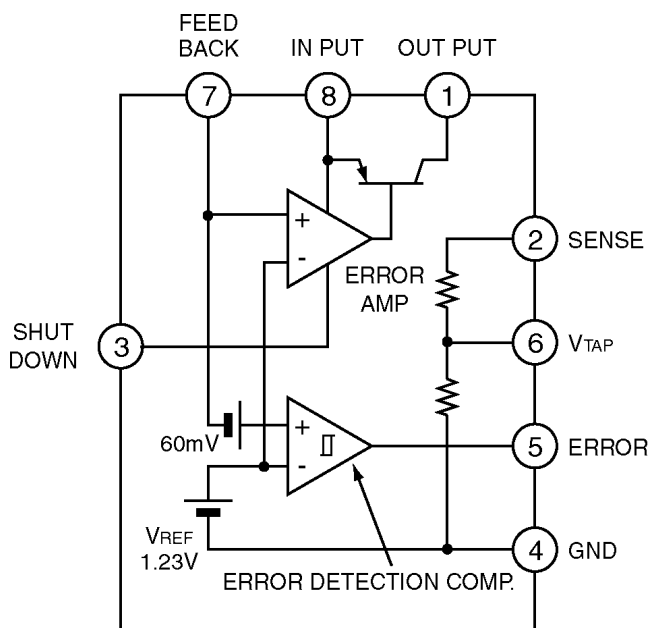

IC706 : YEAM2951MT

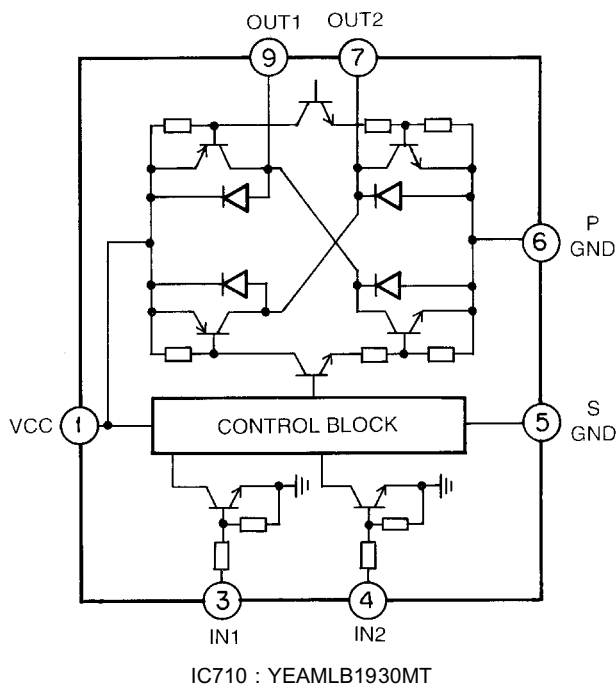

IC710 : YEAMLB1930MT

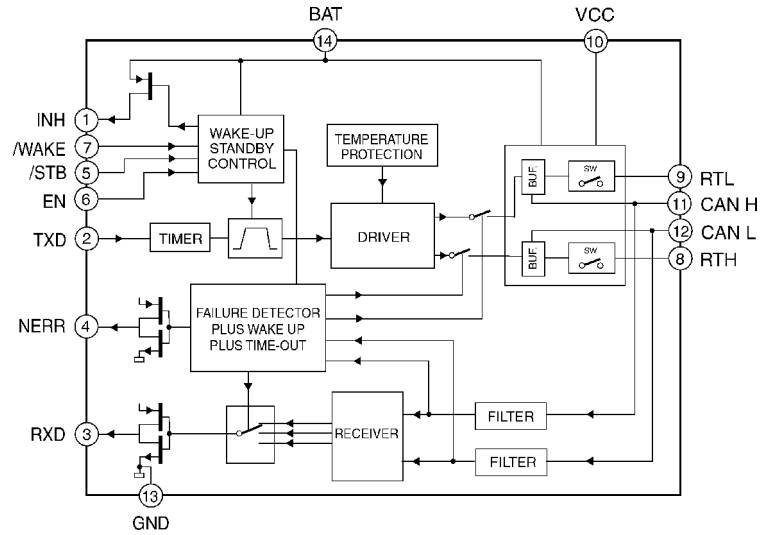

IC707 : C1EB0000039

8.2. CD Servo Block

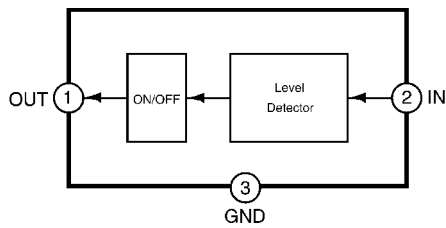

IC714 : MN1382QTX

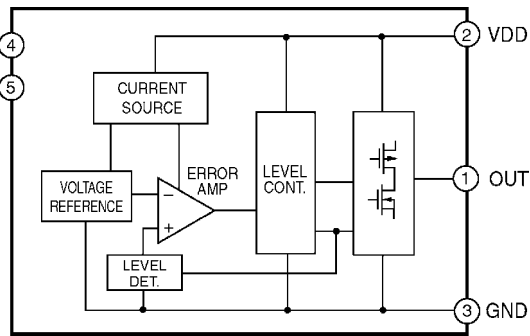

IC715 : C0EBM0000005

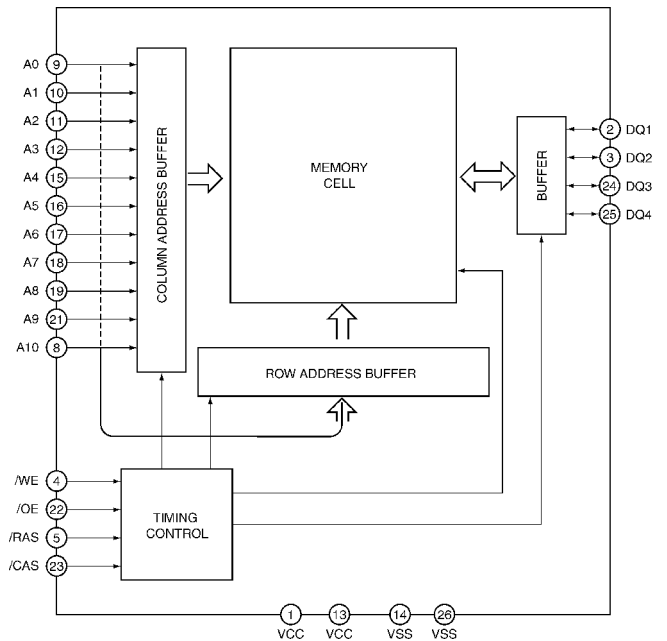

IC403 : C3ABMB0000022

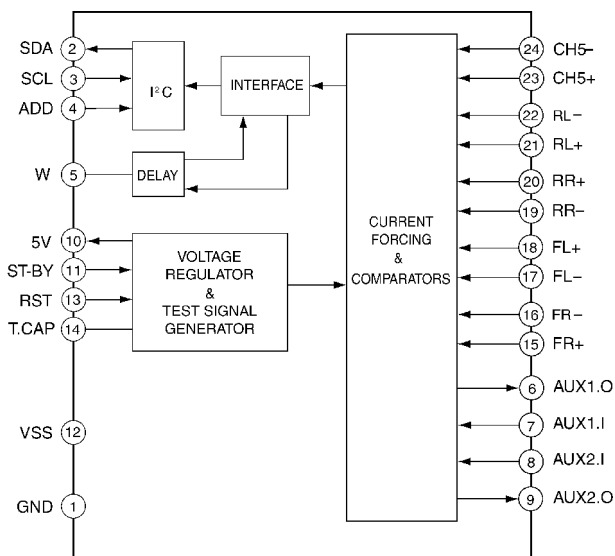

IC881 : C1EB00000042

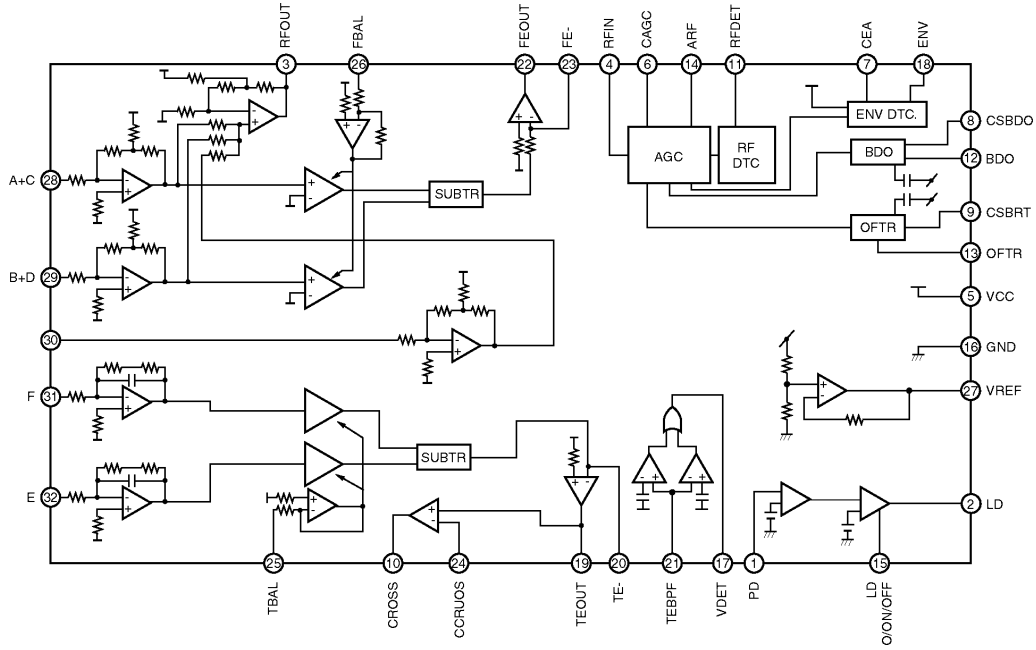

IC404 : C1BB0000173

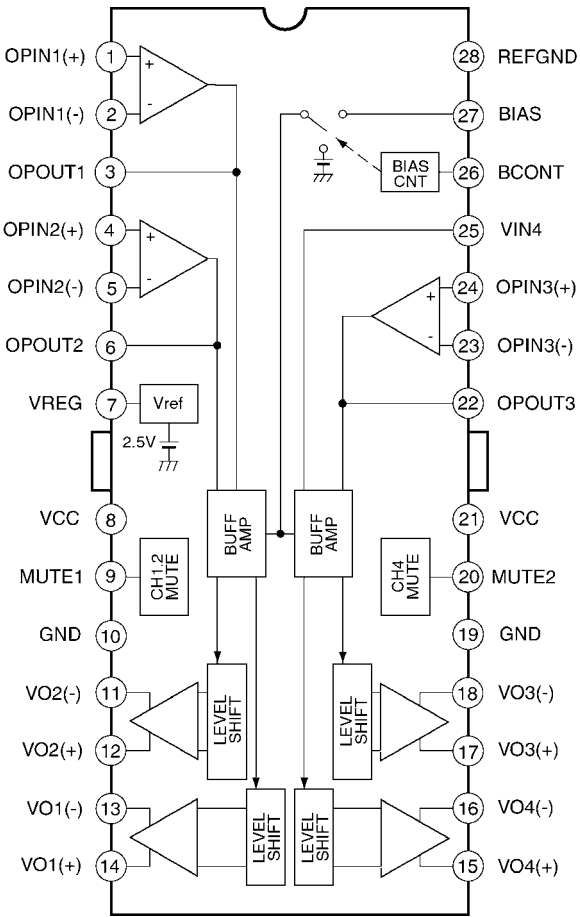

IC405 : C0GBY0000004

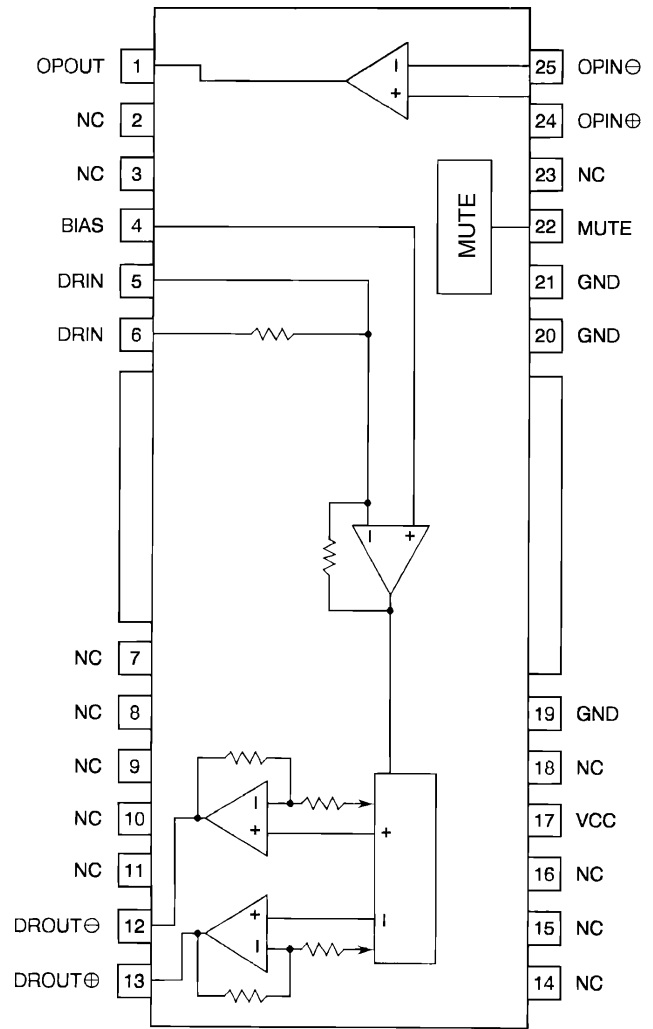

IC406 : C0GBY0000003

9 REPLACEMENT PARTS LIST

Notes :

1. Be sure to make your orders of replacement parts according to this list.
2. Important safety notice: Components, identified by Δ mark have special characteristics important for safety. When replacing any of these components, use only manufacturer's specified parts.
3. Location keys in the remarks column indicates the general location of the parts shown in the exploded drawing, as in a road map.
4. The marking (RTL) indicates that Retention Time is limited for this item. After the discontinuation of assembly in production, the item will continue to be available for a specific period of time. The retention period of availability is dependent on the type of assembly, and in accordance with the laws governing part and product retention. After the end of this period, the assembly will no longer be available.
5. "MCC" marks in remarks column are indicated supply parts of Matsushita Communication Industrial Corp. of America (MCC).

Ref. No.	Part No.	Part Name & Description	Remarks
[E6818B] Main/AMP Block			
IC's and TRANSISTORS			
IC102	AN6564NST1	IC	
IC201	YEAMTA7705FL	IC	
IC202	COABCB000005	IC	
IC281	C1BA00000314	IC	
IC701	C2CBKA000001	IC	
IC702	C2HBZY000007	IC	
IC703	C1BB00000408	IC	
IC705	YEAMS2922ADF	IC	
IC706	YEAM2951MT	IC	
IC707	C1EB00000039	IC	
IC708	YEAMC14584BE	IC	
IC709	MN1382JP	IC	
IC710	YEAMLB1930MT	IC	
IC711	COABBA000022	IC	
IC712	YEAM74HC126F	IC	
IC713	COJBZ001229	IC	
IC714	MN1382QTX	IC	
IC715	COEBM0000005	IC	
IC716	COJBAD0000030	IC	
IC881	C1EB00000042	IC	
IC882	C0DBZH000007	IC	
IC883	AN7709F	IC	
IC884	YEAMPC2410HF	IC	
IC885	C0DBZG000005	IC	
IC886	AN78N05	IC	
IC887	AN7808	IC	
PA101	J3CCAB000001	Electronic Tuner	
Q101	B1ABBD000004	Transistor	
Q102	B1GBCFNN0005	Transistor	
Q103	B1GBCFNN0005	Transistor	
Q205	YEANC314TKTX	Transistor	
Q206	YEANC314TKTX	Transistor	
Q305	YEANC314TKTX	Transistor	
Q306	YEANC314TKTX	Transistor	
Q707	YEAN2SK1133T	Transistor	
Q709	B1GBCFJN0005	Transistor	
Q710	B1GBCFJN0005	Transistor	
Q712	YEANFP1F3PT1	Transistor	
Q713	YEANFP1F3PT1	Transistor	
Q714	2SB1073TX	Transistor	
Q715	B1GBCFJN0005	Transistor	

Ref. No.	Part No.	Part Name & Description	Remarks
Q716	B1ADJC000003	Transistor	
Q717	B1ADJC000003	Transistor	
Q718	B1GBCFJN0005	Transistor	
Q719	B1ABCF000044	Transistor	
Q720	YEANFP1F3PT1	Transistor	
Q721	2SB1073TX	Transistor	
Q725	YEANA114EKTX	Transistor	
Q726	B1GBCFJN0005	Transistor	
Q727	2SB1073TX	Transistor	
Q728	B1GBCFNN0005	Transistor	
Q729	YEANC3661TA	Transistor	
Q730	YEANA114EKTX	Transistor	
Q881	B1ABCF000044	Transistor	
Q882	B1GBCFJN0005	Transistor	
Q883	B1ADJC000003	Transistor	
Q884	2SB1073TX	Transistor	
Q885	B1ABCF000044	Transistor	
Q886	2SB946	Transistor	
Q887	B1GBCFNN0005	Transistor	
Q888	2SB1073TX	Transistor	
Q889	2SB1073TX	Transistor	
Q890	B1ABCF000042	Transistor	
Q891	2SB1193	Transistor	
Q892	2SD1328STTX	Transistor	
Q893	B1BBAC000007	Transistor	
Q894	B1GBCFNN0005	Transistor	
Q897	B1GBCFNN0005	Transistor	
Q899	YEANC3661TA	Transistor	
DIODES			
D101	MAZ33600ML	Diode	
D102	MAZ33600ML	Diode	
D702	YEAD1SS355T1	Diode	
D703	YEAD1SS355T1	Diode	
D704	YEAD1SS355T1	Diode	
D705	YEAD1SS355T1	Diode	
D707	YEAD1SS355T1	Diode	
D708	YEAD1SS355T1	Diode	
D709	YEAD1SS355T1	Diode	
D710	YEAD1SS355T1	Diode	
D711	MA721TX	Diode	
D712	YEAD1SS355T1	Diode	
D713	YEAD1SS355T1	Diode	
D720	MA8056LMHTX	Diode	
D721	MA153TX	Diode	
D722	YEAD1SS355T1	Diode	
D723	YEAD1SS355T1	Diode	
D724	YEAD1SS355T1	Diode	
D725	YEAD1SS355T1	Diode	
D726	MA8100LMTX	Diode	
D729	YEAD1SS355T1	Diode	
D733	MA8051MTX	Diode	
D737	MA151WKTX	Diode	
D739	MA151WATX	Diode	
D740	MA8051MTX	Diode	
D741	MA8051MTX	Diode	
D742	YEAD1SS355T1	Diode	
D743	YEAD1SS355T1	Diode	
D744	YEAD1SS355T1	Diode	
D745	YEAD1SS355T1	Diode	
D746	MA8056LMHTX	Diode	
D747	YEAD1SS355T1	Diode	
D748	YEAD1SS355T1	Diode	
D749	YEAD1SS355T1	Diode	
D750	MA8056LMHTX	Diode	
D751	MA8056LMHTX	Diode	
D752	MAZ816000L	Diode	
D753	MAZ816000L	Diode	
D754	YEAD1SS355T1	Diode	
D881	YEADDSM3MA2T	Diode	
D882	YEAD1SS355T1	Diode	
D883	YEAD1SS355T1	Diode	

Ref. No.	Part No.	Part Name & Description	Remarks
R283	ERJ3GEYJ822V	Chip, 8.2k Ω 1/16W	
R291	ERJ3GEYJ473V	Chip, 47k Ω 1/16W	
R292	ERJ14YJ821H	Chip, 820 Ω 1/4W	
R293	ERJ14YJ821H	Chip, 820 Ω 1/4W	
R301	ERJ3GEYJ103V	Chip, 10k Ω 1/16W	
R302	ERJ3GEYJ103V	Chip, 10k Ω 1/16W	
R303	ERJ3GEYJ103V	Chip, 10k Ω 1/16W	
R304	ERJ6GEYJ124	Chip, 120k Ω 1/10W	
R305	ERJ6GEYJ103	Chip, 10k Ω 1/10W	
R306	ERJ6GEYJ332	Chip, 3.3k Ω 1/10W	
R307	ERJ3GEYJ392V	Chip, 3.9k Ω 1/16W	
R309	ERJ6GEYJ391	Chip, 390 Ω 1/10W	
R310	ERJ3GEYJ392V	Chip, 3.9k Ω 1/16W	
R311	ERJ3GEYJ103V	Chip, 10k Ω 1/16W	
R312	ERJ3GEYJ103V	Chip, 10k Ω 1/16W	
R313	ERJ3GEYJ103V	Chip, 10k Ω 1/16W	
R314	ERJ6GEYJ124	Chip, 120k Ω 1/10W	
R315	ERJ6GEYJ103	Chip, 10k Ω 1/10W	
R316	ERJ6GEYJ332	Chip, 3.3k Ω 1/10W	
R317	ERJ3GEYJ392V	Chip, 3.9k Ω 1/16W	
R319	ERJ6GEYJ391	Chip, 390 Ω 1/10W	
R320	ERJ3GEYJ392V	Chip, 3.9k Ω 1/16W	
R321	ERJ3GEYJ124V	Chip, 120k Ω 1/16W	
R322	ERJ6GEYJ124	Chip, 120k Ω 1/10W	
R323	ERJ6GEYJ183	Chip, 18k Ω 1/10W	
R324	ERJ6GEYJ123	Chip, 12k Ω 1/10W	
R325	ERJ6GEYJ334	Chip, 330k Ω 1/10W	
R326	ERJ6GEYJ121	Chip, 120 Ω 1/10W	
R383	ERJ3GEYJ822V	Chip, 8.2k Ω 1/16W	
R391	ERJ3GEYJ473V	Chip, 47k Ω 1/16W	
R392	ERJ14YJ821H	Chip, 820 Ω 1/4W	
R393	ERJ14YJ821H	Chip, 820 Ω 1/4W	
R502	ERJ6GEYJ104	Chip, 100k Ω 1/10W	
R503	ERJ6GEYJ102	Chip, 1k Ω 1/10W	
R507	ERJ6GEYJ104	Chip, 100k Ω 1/10W	
R508	ERJ6GEYJ103	Chip, 10k Ω 1/10W	
R511	ERJ3GEY0R00V	Chip, 0 Ω 1/16W	
R512	ERJ3GEYJ103V	Chip, 10k Ω 1/16W	
R514	ERJ6GEYJ822	Chip, 8.2k Ω 1/10W	
R518	ERJ3GEYJ102V	Chip, 1k Ω 1/16W	
R519	ERJ6GEYJ102	Chip, 1k Ω 1/10W	
R522	ERJ3GEYJ102V	Chip, 1k Ω 1/16W	
R523	ERJ6GEYJ103	Chip, 10k Ω 1/10W	
R701	ERJ6GEYJ473	Chip, 47k Ω 1/10W	
R702	ERJ6GEYJ473	Chip, 47k Ω 1/10W	
R705	ERJ6GEYJ473	Chip, 47k Ω 1/10W	
R706	ERJ6GEYJ473	Chip, 47k Ω 1/10W	
R707	ERJ3GEYJ105V	Chip, 1M Ω 1/16W	
R708	ERJ3GEYJ105V	Chip, 1M Ω 1/16W	
R712	ERJ6GEYJ822	Chip, 8.2k Ω 1/10W	
R713	ERJ6GEYJ473	Chip, 47k Ω 1/10W	
R715	ERJ6GEYJ472	Chip, 4.7k Ω 1/10W	
R716	ERJ6GEYJ472	Chip, 4.7k Ω 1/10W	
R718	ERJ6GEYJ472	Chip, 4.7k Ω 1/10W	
R719	ERJ6GEYJ472	Chip, 4.7k Ω 1/10W	
R720	ERJ14YJ102H	Chip, 1k Ω 1/4W	
R721	ERJ3GEYJ223V	Chip, 22k Ω 1/16W	
R723	ERJ6GEYJ105	Chip, 1M Ω 1/10W	
R724	ERJ3GEY0R00V	Chip, 0 Ω 1/16W	
R725	ERJ6GEYJ102	Chip, 1k Ω 1/10W	
R726	ERJ6GEYJ102	Chip, 1k Ω 1/10W	
R727	ERJ6GEYJ102	Chip, 1k Ω 1/10W	
R728	ERJ3GEYJ104V	Chip, 100k Ω 1/16W	
R730	ERJ3GEYJ104V	Chip, 100k Ω 1/16W	
R732	ERJ6GEYJ105	Chip, 1M Ω 1/10W	
R733	ERJ3GEYJ102V	Chip, 1k Ω 1/16W	
R734	ERDS1FVJ1R0	Carbon, 1 Ω 1W	
R735	ERJ3GEYJ102V	Chip, 1k Ω 1/16W	
R736	ERJ3GEYJ102V	Chip, 1k Ω 1/16W	
R737	ERJ3GEYJ183V	Chip, 18k Ω 1/16W	
R738	ERJ3GEYJ104V	Chip, 100k Ω 1/16W	
R739	ERJ6GEYJ104	Chip, 100k Ω 1/10W	
R740	ERJ6GEYJ104	Chip, 100k Ω 1/10W	

Ref. No.	Part No.	Part Name & Description	Remarks
R742	ERJ6GEYJ102	Chip, 1k Ω 1/10W	
R743	ERJ6GEYJ473	Chip, 47k Ω 1/10W	
R744	ERJ6GEYJ103	Chip, 10k Ω 1/10W	
R745	ERJ3GEYJ105V	Chip, 1M Ω 1/16W	
R746	ERJ3GEYJ103V	Chip, 10k Ω 1/16W	
R747	ERJ3GEYJ124V	Chip, 120k Ω 1/16W	
R748	ERJ3GEYJ473V	Chip, 47k Ω 1/16W	
R749	ERJ3GEYJ104V	Chip, 100k Ω 1/16W	
R752	ERX1SJ6R8E	Metal Film, 6.8 Ω 1W	
R753	ERJ6GEYJ100	Chip, 10 Ω 1/10W	
R754	ERJ3GEYJ561V	Chip, 560 Ω 1/16W	
R755	ERJ6GEYJ561	Chip, 560 Ω 1/10W	
R756	ERJ6GEYJ104	Chip, 100k Ω 1/10W	
R757	ERJ6GEYJ125	Chip, 1.2M Ω 1/10W	
R758	ERJ6GEYJ125	Chip, 1.2M Ω 1/10W	
R759	ERJ6GEYJ474	Chip, 470k Ω 1/10W	
R760	ERJ3GEYJ105V	Chip, 1M Ω 1/16W	
R761	ERJ3GEYJ153V	Chip, 15k Ω 1/16W	
R762	ERJ6GEYJ103	Chip, 10k Ω 1/10W	
R764	ERJ6ENF1202V	Chip, 12k Ω 1/10W	
R765	ERJ3GEYJ104V	Chip, 100k Ω 1/16W	
R766	ERJ6ENF1002	Chip, 10k Ω 1/10W	
R767	ERJ3GEYJ682V	Chip, 6.8k Ω 1/16W	
R768	ERJ3GEYJ103V	Chip, 10k Ω 1/16W	
R769	ERJ6GEYJ684	Chip, 680k Ω 1/10W	
R772	ERJ6GEYJ564	Chip, 560k Ω 1/10W	
R774	ERJ6GEYJ104	Chip, 100k Ω 1/10W	
R775	ERGLSJ680E	Metal Oxid, 6.8 Ω 1W	
R776	ERJ3GEYJ102V	Chip, 1k Ω 1/16W	
R778	ERJ8GEYJ103V	Chip, 10k Ω 1/8W	
R779	ERJ6GEYJ222	Chip, 2.2k Ω 1/10W	
R780	ERJ6GEYJ222	Chip, 2.2k Ω 1/10W	
R781	ERJ6GEYJ103	Chip, 10k Ω 1/10W	
R787	ERJ6GEYJ104	Chip, 100k Ω 1/10W	
R788	ERJ6GEYJ473	Chip, 47k Ω 1/10W	
R789	ERJ3GEYJ102V	Chip, 1k Ω 1/16W	
R790	ERJ3GEYJ223V	Chip, 22k Ω 1/16W	
R792	ERDS1FVJ1R5	Carbon, 1.5 Ω 1/2W	
R793	ERJ6GEYJ472	Chip, 4.7k Ω 1/10W	
R794	ERJ6GEYJ472	Chip, 4.7k Ω 1/10W	
R795	ERJ3GEYJ392V	Chip, 3.9k Ω 1/16W	
R796	ERJ3GEYJ392V	Chip, 3.9k Ω 1/16W	
R797	ERJ3GEYJ684V	Chip, 680k Ω 1/16W	
R798	ERJ3GEYJ564V	Chip, 560k Ω 1/16W	
R799	ERJ3GEYJ104V	Chip, 100k Ω 1/16W	
R800	ERJ3GEYJ104V	Chip, 100k Ω 1/16W	
R801	ERJ3GEYJ104V	Chip, 100k Ω 1/16W	
R802	ERJ3GEYJ104V	Chip, 100k Ω 1/16W	
R803	ERGLSJ680E	Metal Oxid, 68 Ω 1W	
R804	ERGLSJ680E	Metal Oxid, 68 Ω 1W	
R806	ERJ6GEYJ473	Chip, 47k Ω 1/10W	
R808	ERJ8GEYJ103V	Chip, 10k Ω 1/8W	
R809	ERGLSJ271E	Metal Oxid, 270 Ω 1W	
R810	ERGLSJ271E	Metal Oxid, 270 Ω 1W	
R811	ERGLSJ271E	Metal Oxid, 270 Ω 1W	
R813	ERJ3GEYJ223V	Chip, 22k Ω 1/16W	
R814	ERJ6GEYJ100	Chip, 10 Ω 1/10W	
R816	ERJ3GEYJ103V	Chip, 10k Ω 1/16W	
R818	ERJ3GEYJ184V	Chip, 180k Ω 1/16W	
R825	ERJ3GEYJ103V	Chip, 10k Ω 1/16W	
R828	ERJ3GEY0R00V	Chip, 0 Ω 1/16W	
R829	ERJ6GEYJ103	Chip, 10k Ω 1/10W	
R835	ERJ6GEYJ223	Chip, 22k Ω 1/10W	
R836	ERJ8GEYJ222V	Chip, 2.2k Ω 1/8W	
R837	ERJ3GEYJ223V	Chip, 22k Ω 1/16W	
R838	ERJ8GEYJ471V	Chip, 470 Ω 1/8W	
R843	ERJ3GEY0R00V	Chip, 0 Ω 1/16W	
R844	ERJ6GEYJ685	Chip, 6.8M Ω 1/10W	
R846	ERJ3GEY0R00V	Chip, 0 Ω 1/16W	
R847	ERJ3GEY0R00V	Chip, 0 Ω 1/16W	
R849	ERJ3GEY0R00V	Chip, 0 Ω 1/16W	
R850	ERJ3GEY0R00V	Chip, 0 Ω 1/16W	
R869	ERJ6GEYJ473	Chip, 47k Ω 1/10W	

Ref. No.	Part No.	Part Name & Description	Remarks
[E8898A] Display Block			
IC's and TRANSISTORS			
Q651	B1GBCFNN0005	Transistor	
Q652	YEANFPLF3PT1	Transistor	
Q653	B1GBCFNN0005	Transistor	
Q654	YEANFPLF3PT1	Transistor	
Q655	YEAN2SK536TB	Transistor	
DIODES			
D651	B3AAB0000062	Diode	
D652	B3AAB0000062	Diode	
D653	B3AAB0000062	Diode	
D654	B3AAB0000062	Diode	
D655	B3AAB0000062	Diode	
D656	B3AAB0000062	Diode	
D657	B3AAB0000062	Diode	
D658	B3AAB0000062	Diode	
D659	B3AAB0000062	Diode	
D660	B3AAB0000062	Diode	
D661	B3AAB0000062	Diode	
D662	B3AAB0000062	Diode	
D663	B3AAB0000062	Diode	
D664	B3AAB0000062	Diode	
D665	B3AAB0000062	Diode	
D666	B3AAB0000062	Diode	
D667	B3AAB0000062	Diode	
D668	B3AAB0000062	Diode	
D669	B3AAB0000062	Diode	
D670	B3AAB0000062	Diode	
D671	B3AAB0000062	Diode	
D672	B3AAB0000062	Diode	
D673	B3AAB0000062	Diode	
D674	B3AAB0000062	Diode	
D675	B3AAB0000062	Diode	
D676	B3AAB0000062	Diode	
D677	B3AAB0000062	Diode	
D678	B3AAB0000062	Diode	
D679	B3AAB0000062	Diode	
D680	B3AAB0000062	Diode	
D681	B3AAB0000062	Diode	
D682	B3AAB0000062	Diode	
D683	B3AAB0000062	Diode	
D684	B3AAB0000062	Diode	
D685	YEAD1SS355T1	Diode	
D686	B3AAB0000062	Diode	
D687	B3AAB0000062	Diode	
D688	MA8056LMHTX	Diode	
D689	B3AAB0000062	Diode	
D691	B3AEB0000008	Diode	
D692	B3AEB0000008	Diode	
D693	B3AEB0000008	Diode	
D694	B3AEB0000008	Diode	
D695	B3AEB0000008	Diode	
D696	B3AEB0000008	Diode	
D697	B3AEB0000008	Diode	
D698	B3AEB0000008	Diode	
CAPACITORS			
C651	YECUS1C105ZF	Ceramic, 1 μ F 16WV	
C652	YECUS1H103KX	Ceramic, 0.01 μ F 50WV	
C658	F1K1H104A033	Ceramic, 0.1 μ F 50WV	
C659	F1K1H104A033	Ceramic, 0.1 μ F 50WV	
C660	F1K1H104A033	Ceramic, 0.1 μ F 50WV	
C661	F1K1H104A033	Ceramic, 0.1 μ F 50WV	
C662	F1K1H104A033	Ceramic, 0.1 μ F 50WV	
C664	YECUU1C335KX	Tantalum, 3.3 μ F 16WV	
C665	YECUU1C335KX	Tantalum, 3.3 μ F 16WV	
C666	YECUU1C335KX	Tantalum, 3.3 μ F 16WV	

Ref. No.	Part No.	Part Name & Description	Remarks
RESISTORS			
R651	ERJ6GEYJ105	Chip, 1M Ω 1/10W	
R654	ERJ6GEY0R00	Chip, 0 Ω 1/10W	
R656	ERJ6GEYJ684	Chip, 680k Ω 1/10W	
R657	ERJ6GEYJ124	Chip, 120k Ω 1/10W	
R658	ERJ6GEYJ184	Chip, 180k Ω 1/10W	
R659	ERJ6GEYJ474	Chip, 470k Ω 1/10W	
R660	ERJ6GEYJ105	Chip, 1M Ω 1/10W	
R661	ERJ6GEYJ105	Chip, 1M Ω 1/10W	
R662	ERJ6GEYJ105	Chip, 1M Ω 1/10W	
R663	ERJ6GEYJ105	Chip, 1M Ω 1/10W	
R665	ERJ12YJ390H	Chip, 3.9 Ω 1/2W	
R666	ERJ8GEYJ821V	Chip, 820 Ω 1/8W	
R667	ERJ8GEYJ821V	Chip, 820 Ω 1/8W	
R668	ERJ8GEYJ821V	Chip, 820 Ω 1/8W	
R669	ERJ8GEYJ821V	Chip, 820 Ω 1/8W	
R671	ERJ12YJ180H	Chip, 18 Ω 1/2W	
R672	ERJ8GEYJ821V	Chip, 820 Ω 1/8W	
R673	ERJ8GEYJ821V	Chip, 820 Ω 1/8W	
R674	ERJ8GEYJ821V	Chip, 820 Ω 1/8W	
R675	ERJ8GEYJ821V	Chip, 820 Ω 1/8W	
R676	ERJ8GEYJ821V	Chip, 820 Ω 1/8W	
R677	ERJ8GEYJ821V	Chip, 820 Ω 1/8W	
R678	ERJ8GEYJ821V	Chip, 820 Ω 1/8W	
R679	ERJ8GEYJ821V	Chip, 820 Ω 1/8W	
R680	ERJ8GEYJ821V	Chip, 820 Ω 1/8W	
R681	ERJ8GEYJ821V	Chip, 820 Ω 1/8W	
R682	ERJ8GEYJ821V	Chip, 820 Ω 1/8W	
R683	ERJ8GEYJ821V	Chip, 820 Ω 1/8W	
R684	ERJ8GEYJ821V	Chip, 820 Ω 1/8W	
R685	ERJ8GEYJ821V	Chip, 820 Ω 1/8W	
R686	ERJ8GEYJ821V	Chip, 820 Ω 1/8W	
R687	ERJ8GEYJ821V	Chip, 820 Ω 1/8W	
R688	ERJ8GEYJ821V	Chip, 820 Ω 1/8W	
R689	ERJ6GEYJ104	Chip, 100k Ω 1/10W	
R690	ERJ8GEYJ821V	Chip, 820 Ω 1/8W	
R693	ERJ6GEYJ104	Chip, 100k Ω 1/10W	
R694	ERJ6GEYJ105	Chip, 1M Ω 1/10W	
R695	ERJ6GEYJ104	Chip, 100k Ω 1/10W	
R696	ERJ6GEYJ104	Chip, 100k Ω 1/10W	
CONNECTORS			
CN711	YEATKCF06XE	Connector, 6P	
CN712	YEATKCF06XE	Connector, 6P	
CN713	YEATKCF06XE	Connector, 6P	
CN714	YEATKCF06XE	Connector, 6P	
CN715	YEATKCF06XE	Connector, 6P	
LCD			
LCD651	L5DAAKD00001	LCD	
COILS			
L651	J0JCC0000012	Coil	
VARIABLE RESISTORS			
VR651	K9AA015B0030	Variablr resistor	
VR652	K9AA009B0010	Variablr resistor	
THERMISTOR			
R691	D4CC21040005	Thermistor	
[E8899] CD Servo Block			
IC's and TRANSISTORS			
IC21	YEAMPC4570T1	IC	
IC401	MN101C30AAE	IC	
IC402	MN662783RPW	IC	

Ref. No.	Part No.	Part Name & Description	Remarks
R472	ERJ3GEYJ823V	Chip, 82k Ω 1/16W	
R474	ERJ3GEY0R00V	Chip, 0 Ω 1/16W	
R476	ERJ3GEYJ101V	Chip, 100 Ω 1/16W	
R477	ERJ3GEYJ103V	Chip, 10k Ω 1/16W	
R478	ERJ3GEYJ103V	Chip, 10k Ω 1/16W	
R480	ERJ3GEYJ334V	Chip, 330k Ω 1/16W	
R481	ERJ3GEY0R00V	Chip, 0 Ω 1/16W	
CONNECTORS			
CN402	K1MN15A00035	Connector, 15P	
CN403	YEASF15R2E	Connector, 15P	
CN405	K1MN05B00010	Connector, 5P	
CN406	K1MN05B00009	Connector, 5P	
SWITCHES			
SW2	ESE102MH2	Switch	
SW4	YEAS09275	Switch	
CRYSTALS			
XL401	YEXLSTCC737T	Crystal	
XL402	H2D169500005	Crystal	
Mechanical Parts			
MISCELLANEOUS			
FS881	K5Y103200003	Fuse, 10A	△
AE881	YEAT03435	Terminal	
ANT101	K1ZZ00001159	Antenna Connector	
ANT102	K1ZZ00001160	Antenne Connector	
AJ1	YEAJ071287	Cord w/Plug	
AJ2	YEAJ071285	Cord w/Plug	
AP1	YEAP2711	FPC	
AT1	YEATSD00405	Terminal	
1	YEFA031723	Upper Cover	
2	YEFA09687	Side Plate (L)	
3	YEFX0215016	Bracket, Front	
4	YEFX0214970	Bracket, Rear	
5	YEFX0052503	Spring	
10	YEFX0214971	Bracket, CD Deck	
11	YEFX0214972	Bracket, CD Deck	
12	YEOPT8899Z8	PCB w/Component	RTL
20	YEFF011025	Heat Sink	
21	YEFA09688	Side Plate (R)	
22	YEFX0214975	Bracket, ANT	
23	YEF011773	Pad	
25	YEOPT6818Z8	PCB w/Component	RTL
27	YEF011738	Pad, LCD	
28	YEFX0214976	Bracket, SW701	
29	YEFJ05040	Color Rivet	
30	YEF026820C	Escucheon Ass'y	
31	YEF02360B	Knob, VOL./TUNE	
32	YEF02359A	Knob	
33	YEFR07123A	Rubber contact	
34	YEFR07124	Rubber Contact, EJECT/MIX	
35	YEFX0214974	Bracket	
36	YEOPT8898Z8	PCB w/Component	RTL
37	YEFA131510	Case, LCD	
38	YEFX025143	Color Screen	
39	YEFX0012049	Transparent Plate	
40	YEFK06920	Holder, LCD	
41	YEFA05785	Bottom Cover	
42	YEFX0214973	Bracket, VR651/652	
50	YEJT03131	Tapping Screw,	
51	YEJT03120	Tapping Screw,	
52	XQN2+B5FZ	Tapping Screw, M2x5mm	
53	XSN5+16FX	Screw, M5x16mm	
54	XTB2+6GFX	Tapping Screw, M2x6mm	
55	YEJT03263	Tapping Screw,	

Ref. No.	Part No.	Part Name & Description	Remarks
56	YEJT03296	Tapping Screw,	
57	XTB3+6FFX	Tapping Screw, M3x6mm	
58	XTB3+8FFX	Tapping Screw, M3x8mm	
59	XYN2+J4FX	Screw, M2x4mm	

10 EXPLODED VIEW (Unit)

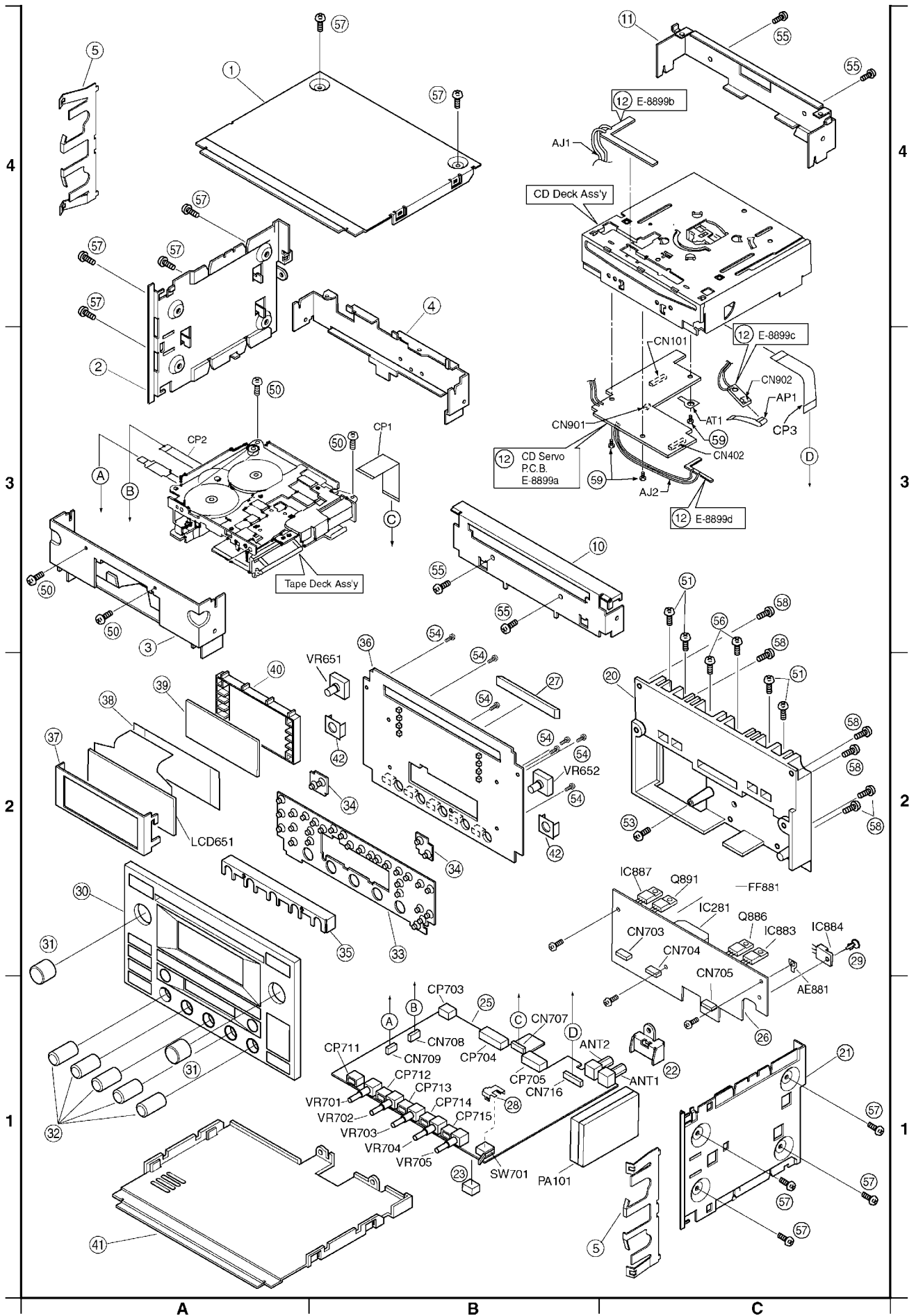

11 CD PLAYER PARTS

MISCELLANEOUS

Ref. No.	Part No.	Part Name & Description	Remarks
1	YGFA011781	Upper Chassis	(4-A)
2	YGFX236153	Disk Guide	(4-A)
3	YGFX0462017	Link Lever	(4-A)
4	YGFX0462018	Detection Lever (2)	(4-B)
5	YGFX0052357	Detection Lever (2) Spring	(4-B)
6	YEJT03131	Tapping Screw, 2.6 mm* 5mm	(2-C) (2-B)
7	YGFX249461	Clamp Arm	(3-A)
8	YGFX007640	Clamper	(3-A)
9	YGFX0052363	Clamper Spring Plate	(3-A)
10	YEFX999957	Ball Bearing	(3-A)
11	YGFX0462013	Detection Lever (1)	(3-A)
12	YGFX0052352	Detection Lever (1) Spring	(3-A)
13	YGFA011795	Suspension Chassis Ass'y	(3-A)
14	YEP0FX3100	Optical Pick-up Ass'y	(3-B)
15	YEFW04150	Feed Screw Housing A	(2-B)
16	YEFW04137A	Feed Screw Housing B	(2-B)
17	YGFX0052386	Thrust Adjusting Spring	(2-B)
18	YEFX236144B	Traverse Guide	(3-A)
19	YGFX9992027	Feed Screw Carrier	(3-B)
20	YEFX9991458A	FPC Holder	(2-A)
21	YGJT03240	Traverse Gear Ass'y	(2-B)
22	YEJS02037	Screw, (Pick-up)	(3-A) (3-B)
23	XYN2+C5FX	Screw, (FPC) 2mm * 5mm	(2-A)
24	XYN2+J10FX	Screw, (Housing) 2mm * 10m	(2-B)
25	YEFX0051590	Spring Washer	(3-A)
26	XUC15V	Retaining Ring, 1.5mm	(3-A)
27	YEFX9991806A	Sealed Plate	(3-B)
28	YGP0FX3503	Traverse Motor Ass'y	(2-B)
29	YEAS23151A	Inner Switch	(2-B)
30	YEFR03080	Rubber Belt	(2-B)
31	YEFX026124A	Idler Pulley	(2-B)
32	YGFX018611	Motor Bracket Ass'y	(2-B)
33	YEJS02018FZ	Screw, (SW)	(2-B)
34	XQN2+A25FX	Screw, 2mm * 25mm	(2-B)
35	YGP0FX3529	Spindle Motor Ass'y	(2-A)
36	YEFX0051991C	Spring (Motor)	(2-A)
37	YGFX0052353	Clamper Spring	(2-A)
38	YGAJ071286	Motor Cable	(2-A)
39	XQN17+A25FX	Screw, 1.7mm * 25mm	(3-A)
40	YGFX0462019	Feeder Arm Ass'y	(1-A)
41	YGP0FX3507	Roller Gear Ass'y	(2-B)
42	YEFW04144	Roller Shaft Collar (1)	(2-A)
43	YEFW04138	Roller Shaft Collar (2)	(2-A)
44	YEFX218282	Rubber Roller	(2-A)
45	YEJW04128	Washer	(2-A)
46	YGFX0052362	Spring (Feeder Arm)	(1-A)
47	YGFX0462015	Suspension Lock Plate (L)	(1-A)
48	YGP0FX3504	Suspension Lock Plate (R) Ass'y	(1-B)
49	YGFX0052355	Spring (Rack Gear)	(1-A)
50	YGFX0052356	Spring (Rack Lock Lever)	(1-B)
51	YGFX0052360	Spring (Suspension Lock Plate L)	(1-A)
52	YGFX0052361	Spring (Lock Plate)	(3-C)
53	YGFA011779	Bottom Chassis Ass'y	(3-C)
54	YGFX003940	Driving Gear (1)	(3-C)
55	YGFX003941	Driving Gear (2)	(3-C)
56	YGP0FX3506	Loding Motor Ass'y	(3-C)
57	YGFX018605	Loding Motor Bracket Ass'y	(3-C)
58	XQN2+A25FX	Screw, (Motor) 2mm * 25mm	(3-C)
59	YEJS06188	Screw	(2-C)
60	YEFS04693	Oil Dumper	(1-C)
61	YGFX0052358	Suspension Spring (A)	(2-C)
62	YGFX0052359	Suspension Spring (B)	(2-C)

13 TAPE PLAYER PARTS

Ref. No.	Part No.	Part Name & Description	Remarks
[E8927A] Tape Reel Block			
RESISTORS			
J1	ERJ8GEY0R00V	Chip, 0 Ω 1/8W	
J2	ERJ8GEY0R00V	Chip, 0 Ω 1/8W	
J3	ERJ8GEY0R00V	Chip, 0 Ω 1/8W	
J4	ERJ8GEY0R00V	Chip, 0 Ω 1/8W	
J5	ERJ8GEY0R00V	Chip, 0 Ω 1/8W	
J6	ERJ8GEY0R00V	Chip, 0 Ω 1/8W	
J7	ERJ8GEY0R00V	Chip, 0 Ω 1/8W	
J8	ERJ8GEY0R00V	Chip, 0 Ω 1/8W	
R1	ERJ8GEYJ683V	Chip, 68k Ω 1/8W	
R2	ERJ8GEYJ683V	Chip, 68k Ω 1/8W	
R3	ERJ8GEYJ472V	Chip, 4.7k Ω 1/8W	
R4	ERJ8GEYJ472V	Chip, 4.7k Ω 1/8W	
R5	ERJ8GEYJ472V	Chip, 4.7k Ω 1/8W	
R6	ERJ8GEYJ472V	Chip, 4.7k Ω 1/8W	
R7	ERJ8GEYJ821V	Chip, 820 Ω 1/8W	
R8	ERJ8GEYJ821V	Chip, 820 Ω 1/8W	
CONNECTOR			
CN2	YEAE012406	Connector, 10P	
SWITCHES			
SW4	K0F111B00047	Switch	
SW5	K0G131E00001	Rotary Switch	
[E8928] SW Block			
DIODE			
D1	B0EANM000002	Diode	
CAPACITOR			
C1	F1K1E334A022	Ceramic, 0.33 μ F 25WV	
RESISTOR			
R2	ERDS2TJ472	Carbon, 4.7k Ω 1/4W	
CONNECTOR			
CN1	YEAE012405	Connector, 7P	
SWITCHES			
SW2	YEAS07174	Switch	
SW3	YEAS08042	Switch	
Mechanical Parts			
MISCELLANEOUS			
1	YGFX0052472	Lock Plate Spring	
2	YGFX0052454	Spring	
3	YGFX0462100	Cassette Holder (U) Ass'y	
4	YGFX0462104	Cassette Holder (L)	
5	YGFA011830	Head Chassis Ass'y	
6	YGFX234194	Cam	
7	YGFX0052427	Back Tension Spring	
8	YGFX209271	Reel (R) Ass'y	
9	YGFX0052471	Holding Spring	
10	YGJW04131	Washer	
11	YGFX0052475	Lack Plate Spring	
12	YGFX0031035	Lack Plate	
13	YGFA011827	Main Chassis Ass'y	
14	YGFX0052444	EQ Lever Spring	
16	YGPOPT8928A0	SW P.C.B. Ass'y	
17	YGP9FZ2993	Head Ass'y	

Ref. No.	Part No.	Part Name & Description	Remarks
18	YGFX0462105	Lever	
19	YGFX0052478	Vibration-proof Spring	
20	YGFX0052477	Spring	
21	YGFX239470	Cassette Guid Plate	
22	YGFX0462097	PRO Change Plate	
23	YGFX0031031	Idler Gear Plate (F) Ass'y	
24	YGPOFX3845	Main Motor Ass'y	
25	YGFX0052474	Lack Return Spring	
26	YGFX218305	Pinch Roller (F) Ass'y	
28	YGFX0031033	Idler Gear Plate (R) Ass'y	
29	YGFX0462102	Lack Return Link	
30	YGFW062600	Lack Return Link Shaft	
31	YGFX218306	Pinch Roller (R) Ass'y	
32	YGFX213213	Flywheel Ass'y	
33	YGFX0031001	Drive Gear (2)	
34	YGFX0031004A	Lack Return Gear	
35	YGFX014075	Lock Ling	
36	YGFX003970	Gear	
37	YGJT03250	Gear Shaft	
38	YGFX0052446	Idler Gear Plate Spring	
39	YGFX0031030	Worm Gear	
40	YGPOFX3846	Loading Motor Ass'y	
41	YGFX030102	Worm Gear Stopper	
42	YGFX0031026	Drive Gear (3)	
43	YGFA011851	Drive Chassis Ass'y	
44	YGPOPT8927A0	Reel P.C.B. Ass'y	
46	YGFX209270	Reel (F) Ass'y	
47	YGFX0052473	Pinch Roller Spring	
50	YGFX003971	PRO Change Gear	
52	YEFR03083	Belt	
54	YGFX0031029	Drive Gear	
61	YEJE01004	E-Ring	
62	YEJE01036	E-Ring	
63	YGFW062546	Screw	
64	XYN2+C8FX	Screw, 2 x 8mm	
65	YEJT03167	Screw,	
66	YEJS06097A	Screw, 2 x 2.5mm	
67	YGJT03271	Screw,	

14 EXPLODED VIEW (Tape Deck)

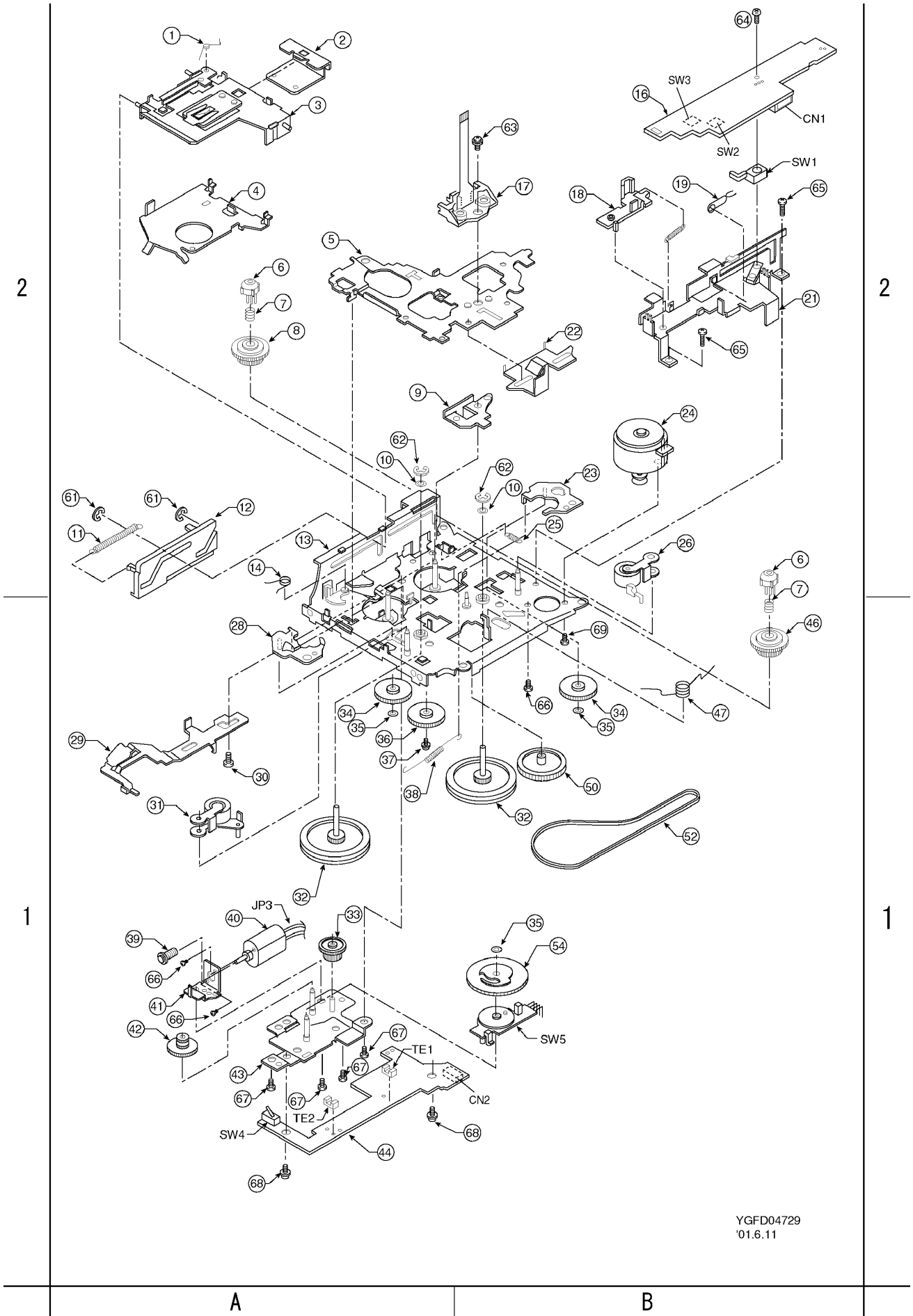

YGFD04729
'01.6.11

16.2. CD Servo Block

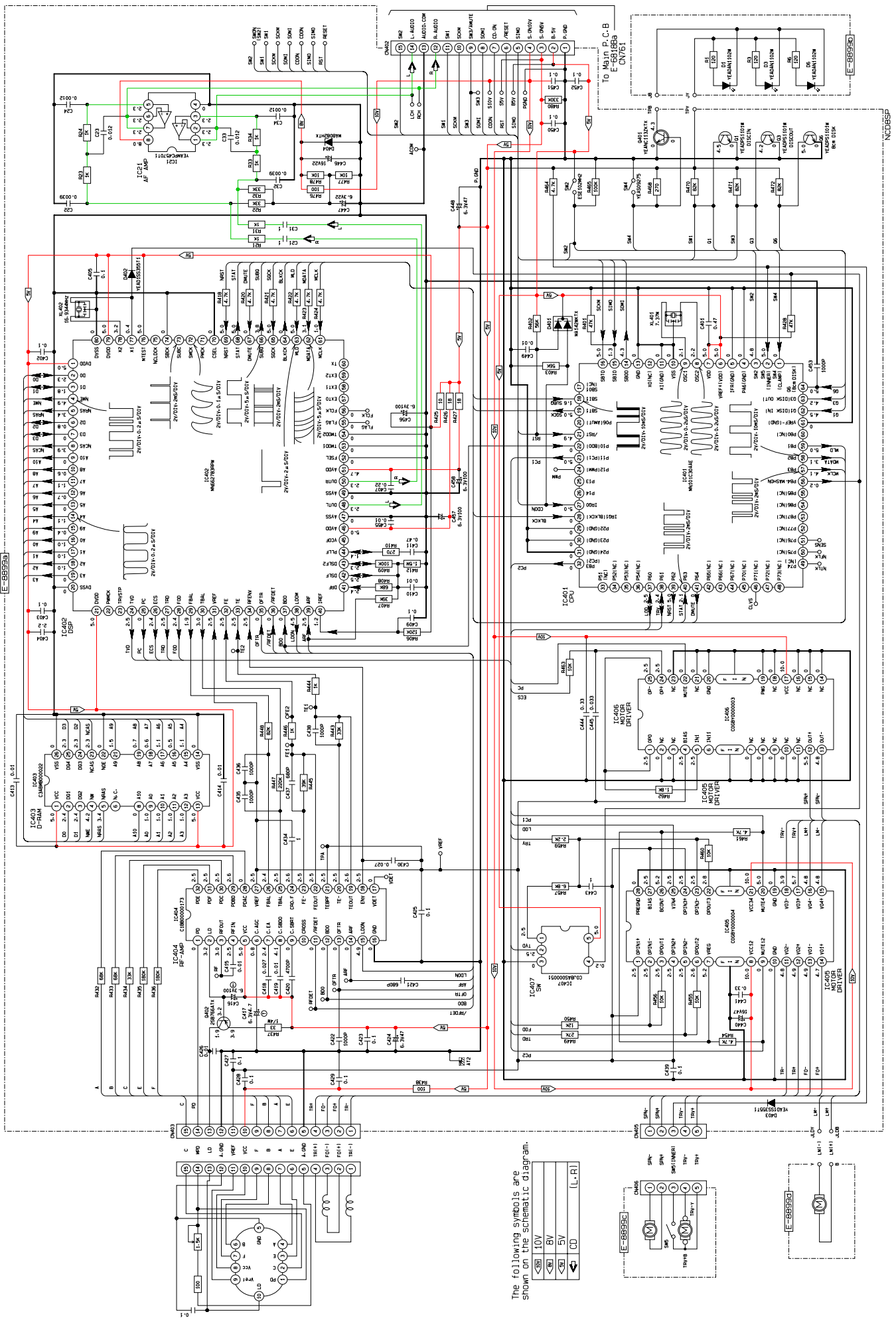

The following symbols are shown on the schematic diagram.

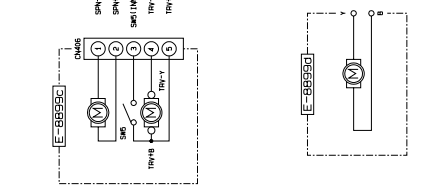

16.4. Display Block

